

Operation Manual

Model: SC-UA04

Name: 40W FPSC Module S



TWINBIRD CORPORATION
SC Business Operation

1. Warning/ Caution

The Stirling cooler (Free Piston Stirling Cooler, FPSC) must be used with a 12 V DC power source. Internal damage can result from operating this Stirling cooler directly with any input voltage other than 12 V DC.

- (1) The Stirling cooler is designed for use in ambient temperatures between 0 – 40 deg. C.
Internal damage could result from operating the Stirling cooler outside this temperature range.
- (2) The cold side of the Stirling cooler should be maintained between –50 and +10 deg. C. Operation outside of this temperature range could result in internal damage to the Stirling cooler. To avoid the possibility of damaging to internal parts by overheating the Stirling cooler, do not apply heating elements directly to the cold side.
- (3) Use caution when handling the Heat Reject Fin assembly to prevent damage or injury. Inspect the Heat Reject Fin assembly for deformity or breakage before use.
- (4) Reduce the output setting of the Stirling cooler if unusual noises are observed coming from inside the pressure vessel. Please contact Twinbird if the reduced output setting does not eliminate the unusual noises.
- (5) Avoid subjecting the Stirling cooler to excessive shock, it could cause internal damage.
- (6) Direct exposure of the Stirling cooler and PCB to water could cause electrical failure.
- (7) Direct exposure of the Stirling cooler and PCB to fire or excessive heat could cause internal damage.
- (8) Warning: Placing the Stirling cooler into fire or excessive heat could cause expansion of the contained gas and explosion.
- (9) Do not put excessive strain on the electrical cords. It could cause damage to the wire and cause the Stirling cooler stop operating.
- (10) To avoid the danger of burns, avoid touching the heat reject fin and certain parts on PCB with your bare hands during or immediately after operation.
- (11) To avoid the danger of frostbite, avoid touching the cold side and its immediate surroundings with your bare hands during or immediately after operation.
- (12) Please provide thermal insulation around cold side to prevent frost and dew condensation. If conditions require that you need to operate the Stirling cooler without thermal insulation, the cold side may develop a coating frost or water. If this occurs, please clean the cold side with a soft cloth. Having frost or condensation on the cold side surface can cause an apparent reduction of cooling capacity. Also, if water drips down on a power cord or balancer as it defrosts, it could cause a short circuit or corrosion.
- (13) Failure of the Stirling cooler could result from subjecting the cold side to a strong impact force. It is made of thin stainless steel sheet surrounding a precision interior structure.
- (14) The Stirling cooler uses a high pressure gas inside, please contact Twinbird if you intend to scrap the Stirling cooler.
- (15) The Field Of Application and Restriction Of Export



FPSC Products are produced under License Agreement with Global Cooling BV.
Said License Agreement stipulates some restrictions for manufacturing, sales and field of application for FPSC Products.

Therefore, we cannot produce an FPSC Product in the fields of application as follows:

1. Cooling to temperatures under 150 Kelvin (about -125deg.C)
 2. Petroleum testing and oil exploration
 3. Electric appliances for household use
- *Please feel free to contact us if you have question about the field of application.

The following regulations shall be applied to Stirling cooler export. Permission for export from the Minister Of Economy, Trade And Industry is required before exporting Stirling coolers from Japan.

- Foreign Exchange And Foreign Trade Law – section 1 of article 48
 - Foreign Exchange And Foreign Trade Law – section 1 of article 67
 - Export Trade Control Ordinance – section 2 of article 8
- *If you wish to export our Products from Japan, please contact us prior to exporting.
- *The above regulations were applicable as of November 27, 2003.
- *Laws and regulations may be changed in accordance with legal revisions.

2. Specification

(1) Exterior

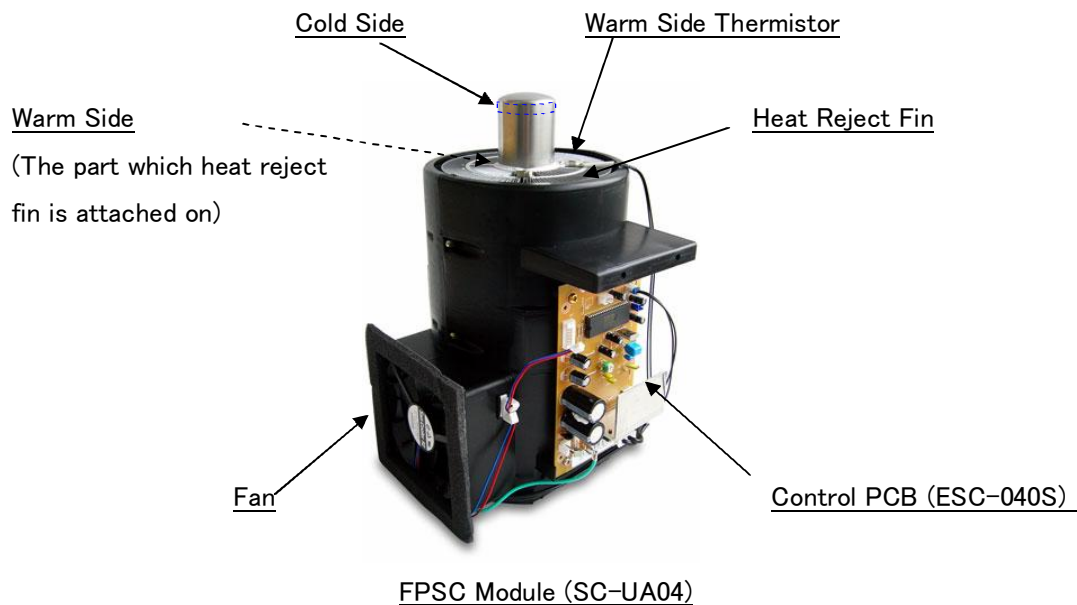

(2) Main Specification

No.	Item	Specification
1	Size	W 173 x D 186 x H 279 mm
2	Weight	Approximately 3 kg
3	Refrigerant	(He) Helium
4	Amount of Refrigerant	2.5 g
5	Internal Pressure	2.6 MPa
6	Power Source	DC 12 V for Drive PCB
7	Cooling Capacity	35 W or Over [Condition] Cold Side Temperature: -23.3 deg. C Ambient Temperature: 25 deg. C Input Voltage to Set Output Voltage: 5V
8	Controllable Temperature Range	-30 ~ +10 °C
9	Power Consumption	60 W or Less
10	Ambient Temperature Range to Use	0 ~ 40 °C
11	Acceptable Temperature Range at Cold Side	-50 ~ +10 °C
12	Accessories (attached on FPSC module)	Control PCB (ESC-040S)

(3) Typical Graph of Cooling Capacity

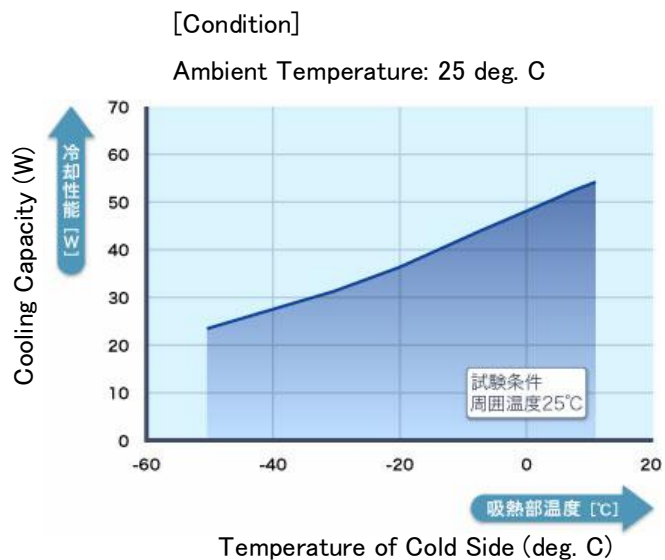

Wiring Connections

Here are common wiring connections at Fixed Output Operation and Temperature Control Operation.

Warm side thermistor (1), FPSC (2) and earth wire (3) should be connected as follows.

There is no integrated power supply connector for the fan on the PCB. The cooling fan must be provided with a 12 VDC power supply.

(1) Warm Side Thermistor	Specification	Pin#
	Warm side	1
	temperature input	2

PCB outputs emergency signal and stops FPSC when the temp. is 54 °C or higher, the terminals are open or short circuit.

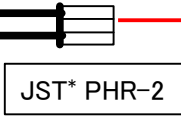

(2) Output to FPSC	Specification	Pin#
	Output to FPSC	1
		2

Output Voltage range: 2.0 – 8.5 V AC (RMS)
Output Current Capacity: 6.9 A (RMS)

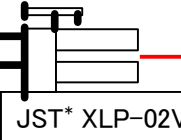

(3) Earth Wire	Specification	Pin#
	GND (DC0V)	-

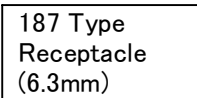

(4) Power Supply for Fan	Specification	Pin#
	GND (DC 0V)	1
	DC 12V	2

Specification of Power Supply
Output Voltage: 12 V DC (+/- 1.2 V)
Current Capacity: 0.12 A or over 以上

[Warning]
Use caution around moving elements of fan during operation.

*JST Mfg. Co., Ltd.

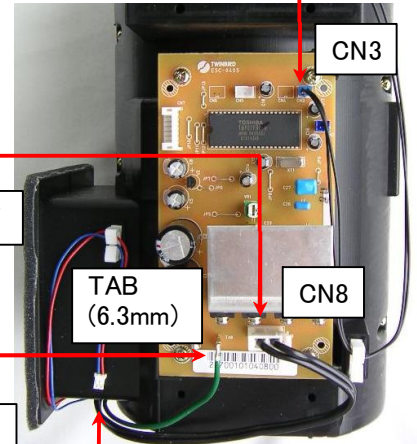

This connector should be put on PCB. If you connect fan to power supply directly, please cut off the connector from lead wires, and connect the wires as following.

Specification	Color of read wire
GND (0V DC)	Blue
12V DC	Red

An Example of Connection at Fixed Output Operation

Connect volume (1), switch (2), power supply for PCB (3) and power supply for fan as follows.

(1) Output Setting	Specification	Pin#
	DC 5V DC	1
	Output Setting	2
	GND (0V DC)	3

Connect volume (10 k ohm or over).
You can put 1 to 5 V DC to Pin # 2.

Setting	Cooling Capacity
1 V or Lower	Min.
5 V	Max.

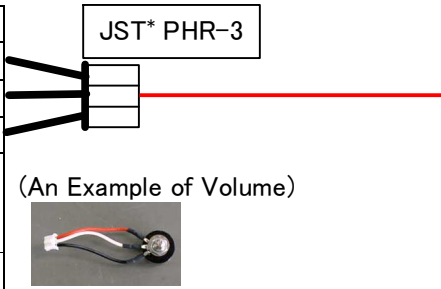

(2) Drive Stop	Specification	Pin#
	GND (0 V DC)	1
	(Temp. Setting)	2
	(Emergency Signal)	3
	(Driving Status Signal)	4
	Drive / Stop	5
	(Operation Mode)	6
	(Reset)	7
	(5 V DC)	8

Connect switch between Pin #1 and #5.

SW	Function
ON	Drive
OFF	Stop

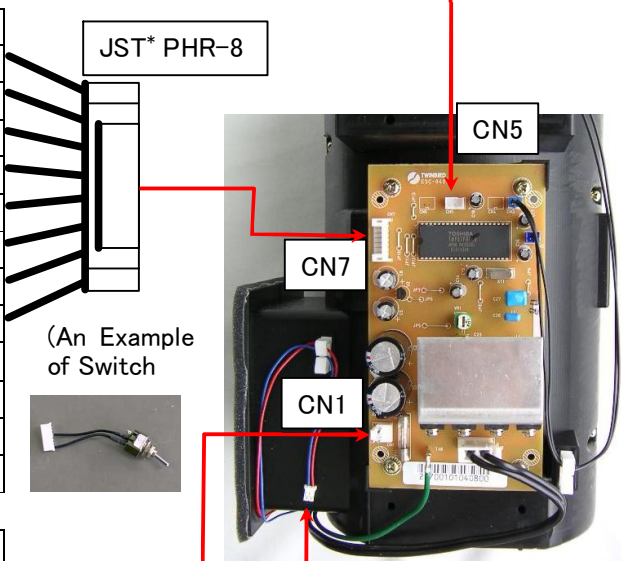

(3) Power Supply for PCB	Specification	Pin#
	12V DC (Typical)	1
	GND (0V DC)	2

Specification of Power Supply
Output Voltage Range: 10 – 16 V DC
Output Current Capacity: 6 A (RMS) or Over

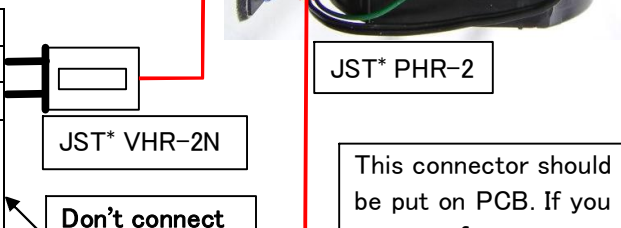

(4) Power Supply for Fan	Specification	Pin#
	GND (0V DC)	1
	12V DC	2

Specification of Power Supply
Output Voltage: 12 V DC (+/- 1.2 V)
Current Capacity: 0.12 A or over

[Warning]
Use caution around moving elements of fan during operation.

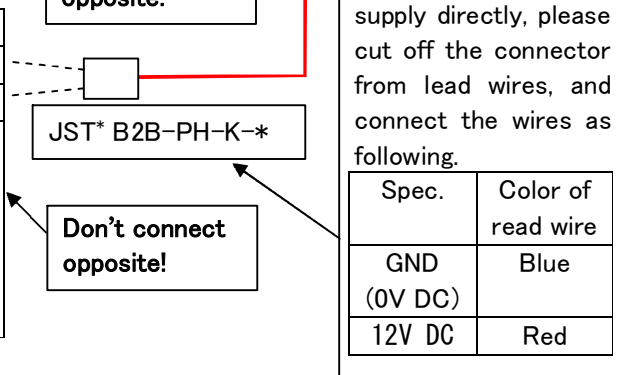

*JST Mfg. Co., Ltd.

3-A-2 Procedure to Use at Fixed Output Operation

(a) Start-up Procedure

- (1) Set potentiometer output to a minimum value. (Output setting volume is 1 V or lower)
- (2) Connect power supply to PCB.
- (3) Turn drive/ stop switch to the ON position. FPSC will start to cool down.
- (4) Adjust cooling capacity with potentiometer.

[Notes] Abnormal sounds or noise may come out from FPSC right after start-up when the potentiometer output voltage is set at a high level. To prevent this, please reduce output setting voltage to 1 V or lower then raise it slowly.

(b) Shut-down Procedure

- (1) Reduce output setting voltage to 1V or lower by the volume.
- (2) Turn drive / stop switch OFF.
- (3) Cut off power supply to PCB and fan.

An Example of Connection at Temperature Control Operation

Connect control thermistor (1), read wires (2), switch (3), volume (4), power supply for PCB (5), power supply for fan (6).

(1) Control Thermistor	Specification	Pin#
	Control	1
	Temperature Input	2
To sense the temperature to control, connect the thermistor "PT-51F" manufactured by Shibaura Electronics Co., LTD.		

JST* PHR-2 (An Example of Thermistor)

[Note] PCB outputs emergency signal and stop FPSC when the temp. is 54 deg. C or higher, the terminals are open or short circuit.

(2) - (4)	Specification	Pin#
	GND (0 V DC)	1
	Control Temp. Setting (Emergency Signal)	2
	(Drive Status Signal)	3
	Drive / Stop	4
	Operation Mode (Reset)	5
	5 V DC	6
		7
		8

JST* PHR-8

(2) Temperature Control Operation. Connect a wire between pin #1 and pin #6.		
(3) Drive / Stop	Switch	Function
	ON	Drive
Connect a switch between pin #1 and pin #5.		OFF
		Stop

(An Example of Switch)

(4) Control Temperature Setting	Connect volume (10 k ohm or over). You can put 1 to 5 V DC to Pin # 2.	
---------------------------------	--	--

(An Example of Volume)

(5) Power Supply for PCB	Specification	Pin#
	12V DC (Typical)	1
	GND (0V DC)	2
Specification of Power Supply Output Voltage Range: 10 – 16 V DC Output Current Capacity: 6 A (RMS) or Over		

JST* VHR-2N
Don't connect opposite!

⑥	Specification	Pin#
	GND (DC 0V)	1
	DC 12V	2
Specification of Power Supply Output Voltage: 12 V DC (+/- 1.2 V) Current Capacity: 0.12 A or over [Warning] Use caution around moving elements of fan during operation.		

JST* B2B-PH-K-□
Don't connect opposite!

Temp. Setting vs. Input Voltage	
Input Voltage V (V)	Temp. Setting T (deg. C)
4.85 or over	+15
4.1	+6
3.6	0
3.1	-6
2.1	-18
1.1 or lower	-30

$V=1.1+(30+T)/12$

This connector should be put on PCB. If you connect fan to power supply directly, please cut off the connector from read wires, and connect the wires as following.

Spec.	Color of read wire
GND (0 V DC)	Blue
12 V DC	Red

*JST Mfg. Co., Ltd.

3-B-2. Procedure for Operation Using Temperature Control Mode

(a) Start-up Procedure

- (1) Connect power supply to PCB.
- (2) Adjust temperature setting with potentiometer.
- (3) Turn drive/ stop switch ON and the FPSC will begin to cool down.
- (4) The PCB will control output to the FPSC to maintain temperature set point.

[Notes] Abnormal sounds or noise may come from the Stirling cooler immediately after start-up. To prevent this, please connect a potentiometer to CN5 and adjust it to reduce output setting voltage.

The potentiometer setting determines the maximum output voltage during temperature control operation.

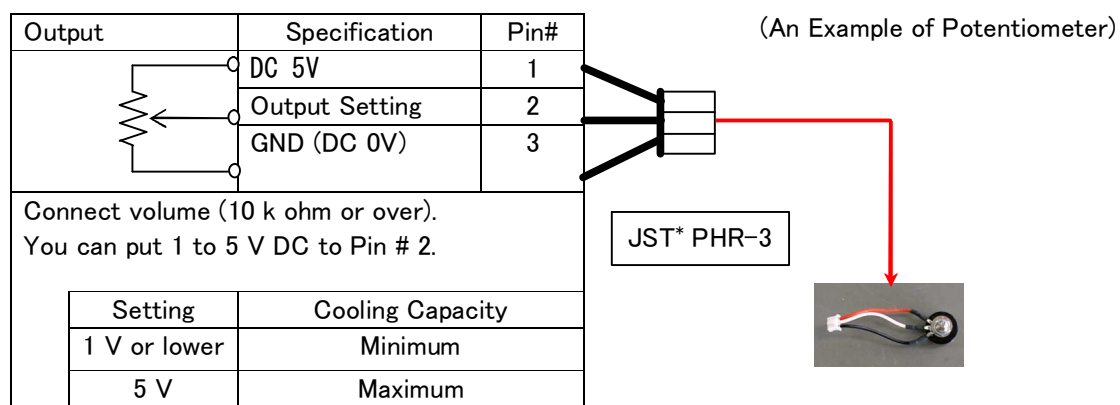

(b) Shut-down Procedure

- (1) Turn drive/ stop switch OFF.
- (2) Cut off power supply to PCB and fan.

4. Function of Control PCB (ESC-040S)

4.1 Outline of Function

This PCB is designed to operate in conjunction with a 40W Free Piston Stirling Cooler (FPSC) and has the following functions.

- (1) To drive FPSC with around 79.1 Hz PWM out-put, it needs to invert from 12 V DC input power.
- (2) To provide the desired drive voltage to the FPSC. The drive voltage is decided by the input voltage (1- 5 V DC) to the control terminal.
- (3) To output drive signal status while FPSC is in operation.
 - (4) The PCB outputs an emergency signal and reduces output to the FPSC when the following conditions are detected.
 - ① When the temperature of the sensor on the warm side is 54 deg. C or higher.

- ② When the temperature of the sensor for temperature control is not between -50 deg. C and $+65$ deg. C during temperature control operation.
- ③ When the temperature sensor is disconnected, the wire is cut or the terminals are shorted.

4. 2 Input /Output explanation

4. 2. 1 Input

(1) Power Supply Input (CN1)

No.	Item	Specification
1	Rating voltage	DC 12 V
2	Allowable voltage	DC 10.8 ~ 13.2 V (DC 12 V \pm 10 %)
3	Maximum input current	6A (RMS) (at 12 V of input voltage)

(2) Control Temperature Input (CN2)

Control Temperature Input is available using Temperature Control Operation.

The temperature to be controlled is sensed and input by a thermistor.

When the sensed temperature is not in the allowable temperature range, the PCB judges that the wire is cut or the terminals are shorted. Then the PCB stops to operate FPSC and outputs emergency signal.

No.	Item	Specification
1	Allowable temperature range	$-50 \sim +65^{\circ}\text{C}$
2	Thermistor	Manufacturer
3		SHIBAURA ELECTRONICS Co., LTD.
4		Resistance
5		Bconst
		PT-51F
		49.12k Ω (at 25 $^{\circ}\text{C}$) 3.3k Ω (at 100 $^{\circ}\text{C}$)
		3970K

(3) Warm Side Temperature Input (CN3)

The warm side temperature is sensed and input by a thermistor.

When the sensed temperature is not in the allowable temperature range, the PCB judges that the wire is cut or the terminals are shorted. Then the PCB stops to operate FPSC and outputs emergency signal.

No.	Item	Specification
1	Allowable temperature range	$-20 \sim +90^{\circ}\text{C}$
2	Thermistor	Manufacturer
3		SHIBAURA ELECTRONICS Co., LTD.
4		Resistance
5		Bconst
		PT-51F
		49.12k Ω (at 25 $^{\circ}\text{C}$) 3.3k Ω (at 100 $^{\circ}\text{C}$)
		3970K



(4) Output Setting Input (CN5)

•Fixed Output Operation

Output voltage to FPSC is decided according to the input voltage (1 – 5 V DC) at this terminal.

•Temperature Control Operation

Maximum output voltage to FPSC is decided according to the input voltage (1 – 5 V DC) at this terminal.

An example setting: Refer to right figure.

(Resistor is 10 k ohm or larger)

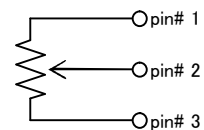

(5) Temperature Setting Input (CN7,pin#2)

Target temperature to be controlled is decided according to the input voltage (1 – 5 V DC) at this terminal.

No.	Item	Specification
1	Setting Voltage Range	DC 1 ~ 5 V
2	Target Temperature Range	-30 ~ +15 °C

An example of target temperatures and setting voltages.

$$V=1.1+(30+T_{set})/12$$

Target Temp.	-30°C	-24°C	-18°C	-12°C	-6°C	0°C	+6°C	+12°C	+15°C
Setting Voltage	1.1V	1.60V	2.10V	2.60V	3.10V	3.60V	4.10V	4.60V	4.85V

An example setting: Refer to right figure.

(Resistor is 10 k ohm or larger)

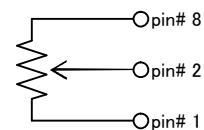

(6) Drive/Stop of FPSC (CN7,pin#5)

Output voltage will be output or not output according to the status of the terminal.

Status of Input Terminal	Function
Open	Drive
Low level	Stop

* : Low level= 0 ~ 1.5V

(7) Operation Mode Input (CN7,pin#6)

Fixed Output Operation or Temperature Control Operation will be selected according to the status of the terminal.

Status of Input Terminal	Function
Open	Fixed Output Operation
Low level	Temperature Control Operation

* : Low level= 0 ~ 1.5V



4. 2. 2 Output Part

(1) Output to FPSC (CN8)

No.	Item	Specification
1	Output wave shape	PWM
2	Frequency	79.1Hz
3	Output voltage range	AC 2.0~8.5 V (RMS)
4	Output current capacity	7A (RMS)

•Fixed Output Operation

Decided output voltage to FPSC will be output.

•Temperature Control Operation

Output voltage to FPSC will be controlled so the sensed temperature will be conducted to setting temperature.

(2)Emergency Signal Output (CN7,pin#3)

The PCB outputs an emergency signal and stop output to the FPSC when the following conditions are detected.

- At Fixed Output Operation:
 - ① When the warm side thermistor is 54 deg. C or higher.
 - ② When the thermistor is disconnected, the wire is cut or the terminals are shorted.

- At Fixed Output Operation:
 - ① When the temperature of the warm side thermistor is 54 deg. C or higher.
 - ② When the temperature of the thermistor for temperature control is not between -50 deg. C and +65 deg. C.
 - ③ When thermistors are disconnected, the wire is cut or the terminals are shorted.

Status	Status of Output Terminal
Normal	High - Impedance
Emergency	Low Level

Output: Open Drain (Max 2mA)

(3) Drive Status Signal Output (CN7,pin#4)

PCB outputs a signal as follows according to the operation of the FPSC.

Status	State of put Terminal
Stop	High -Impedance (DC 4.0 ~ 5.3 V)
Drive	Low Level (DC 0.4 V 以下)

Output: Open Drain (Max 2mA)



(4) Contact

TWINBIRD CORPORATION

SC Business Operation

Person: H. Fujino (sales), K. Sone (R&D)

E-mail: sc@twinbird.co.jp

Phone: +81-256-92-6173

Facsimile: +81-256-93-6168

Address: 2084-2, Nishiota, Yoshida-Machi, Nishikanbara, Niigata 959-0292 Japan